

Corredera de Aluminio para Mamparas de Baño

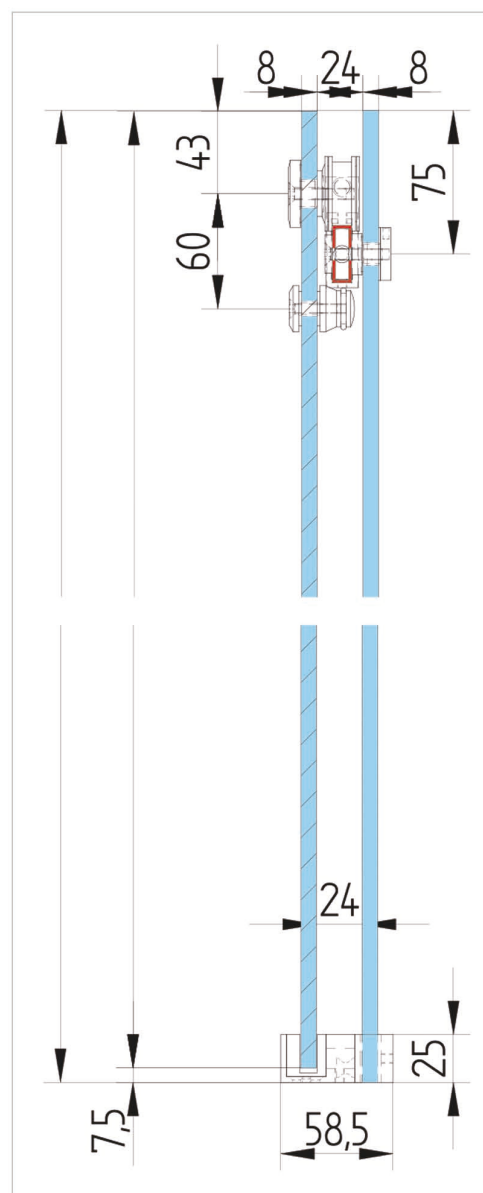

Características Principales

Acero INOX acabado brillo

Peso max: 50 kg/puerta

Vidrio: 8-10 mm (recomendado 8 mm)



90° 2 Puertas

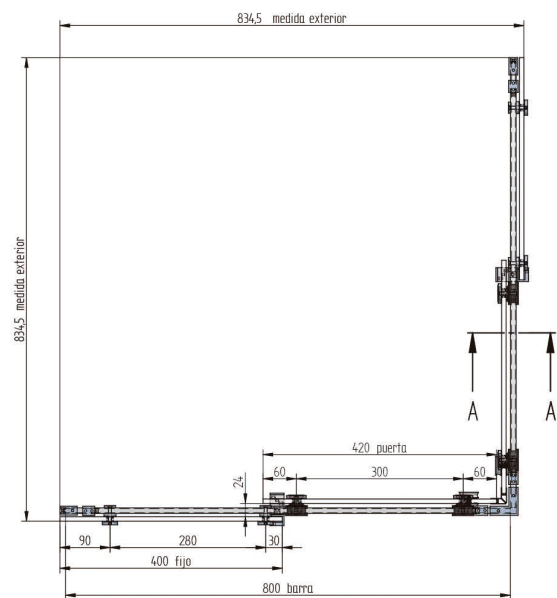
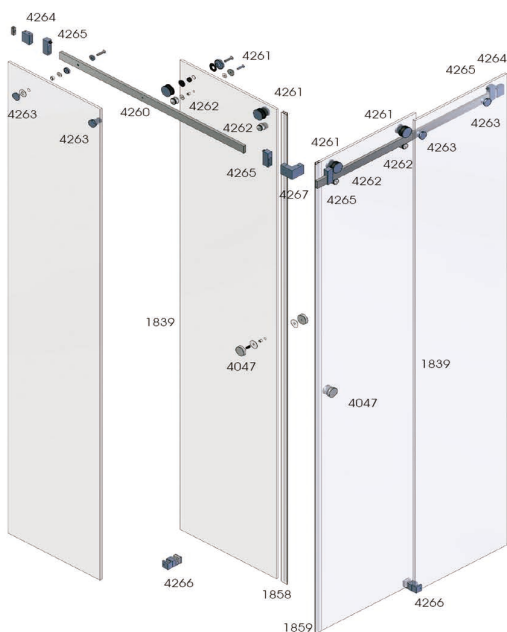
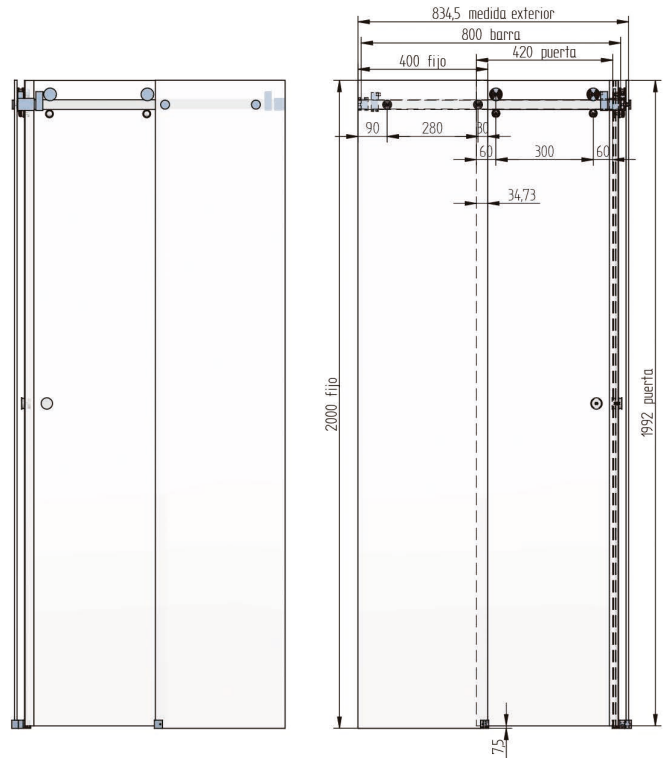

Características Principales

✓ Acero INOX acabado brillo

✓ Peso max: 25 kg/puerta

✓ Vidrio: 8-10 mm (recomendado 8 mm)



Corredera de Aluminio para Mamparas de Baño

90° 1 Puerta

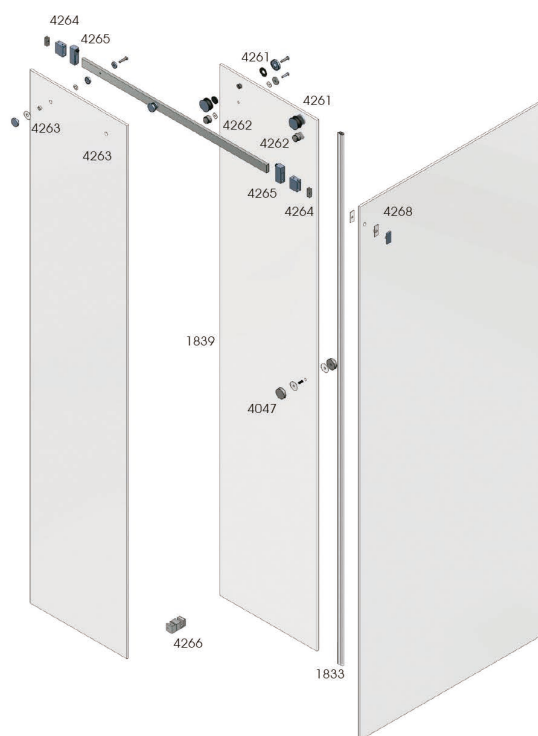
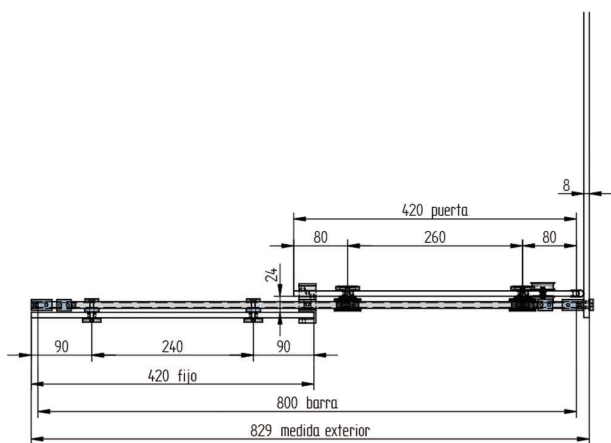
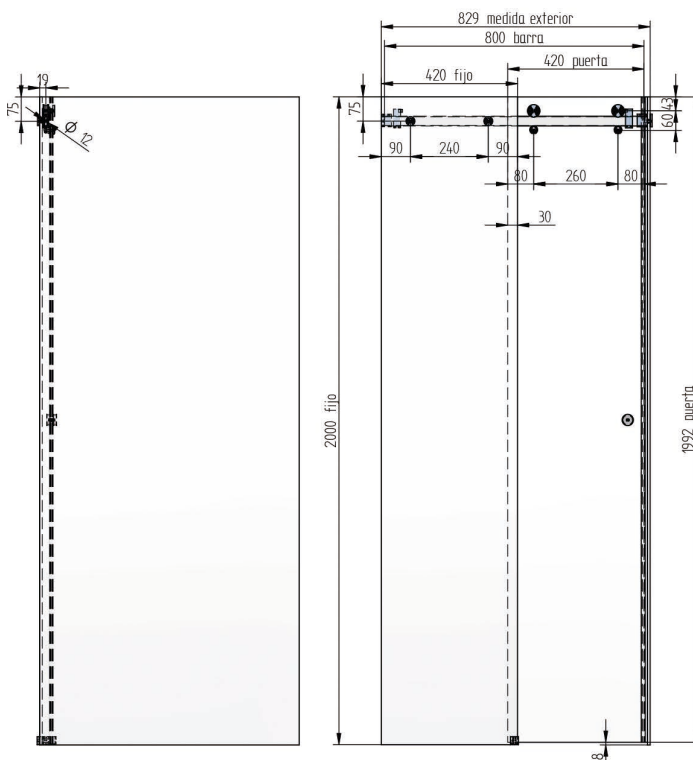

Características Principales

✓ Acero INOX acabado brillo

✓ Peso max: 50 kg/puerta

✓ Vidrio: 8-10 mm (recomendado 8 mm)



Corredera de Aluminio para Mamparas de Baño

180°

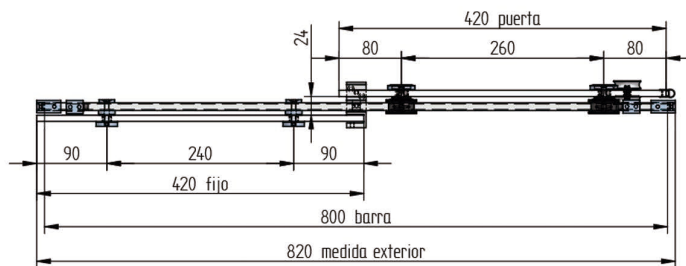
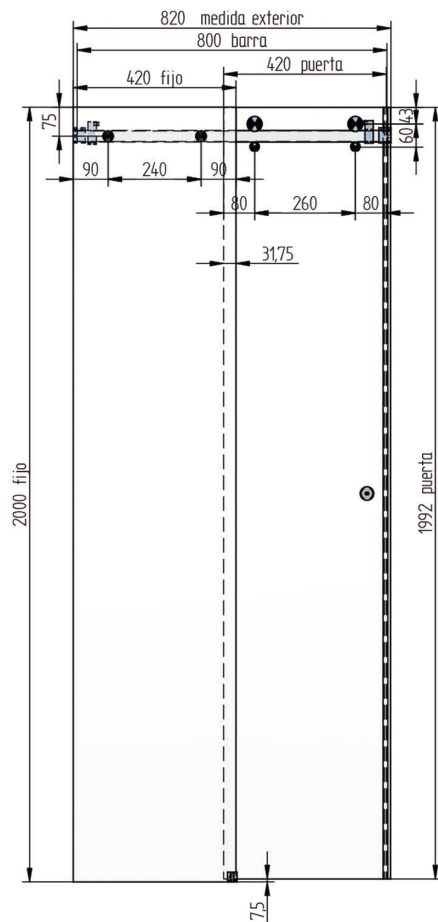
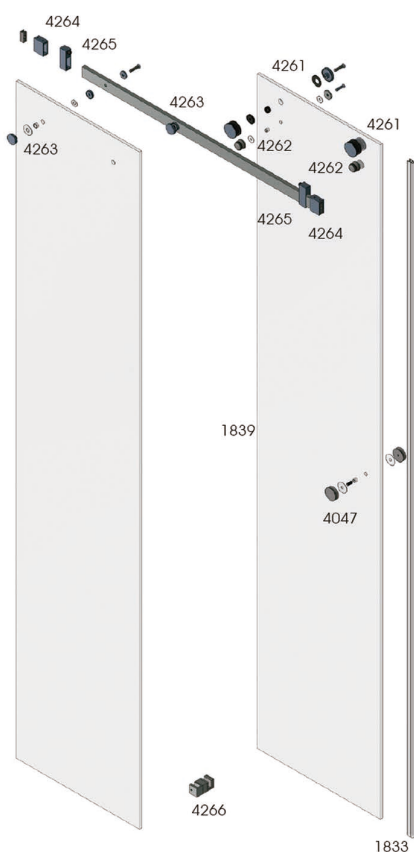

Características Principales

Acero INOX acabado brillo

Peso max: 50 kg/puerta

Vidrio: 8-10 mm (recomendado 8 mm)



Corredera de Aluminio para Mamparas de Baño



inox s.s. 2/3 m \varnothing 6 mm €/m

Carril
Inox brillo
Barras de 2 y 3 m

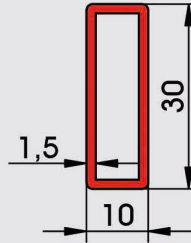

inox s.s. 20 kg/u 8-10 mm \varnothing 15 mm €/u

Cojinete
Inox brillo
Peso max. 40 kg/puerta
Vidrio: 6-8-10 mm (recom: 8 mm)

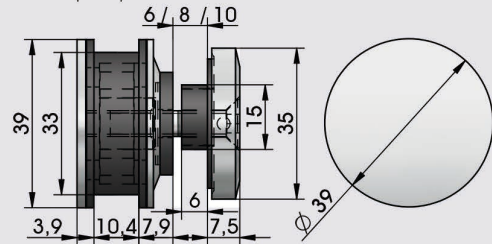

inox s.s. 8-10 mm \varnothing 8 mm €/u

Tope seguridad
Inox brillo
Vidrio: 8-10 mm (recom: 8 mm)

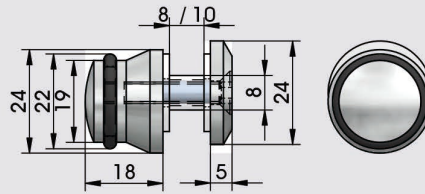

inox s.s. 8-10 mm \varnothing 15 mm €/u

Anclaje vidrio fijo-carril
Inox brillo
Vidrio: 8-10 mm (recom: 8 mm)

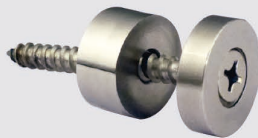
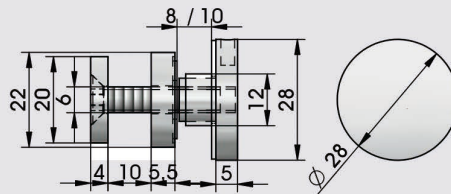

inox s.s. \varnothing 6 mm €/u

Anclaje pared-carril
Inox brillo

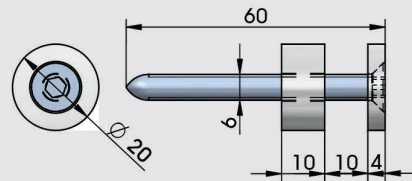

inox s.s. €/u

Anclaje pared-carril
Inox brillo

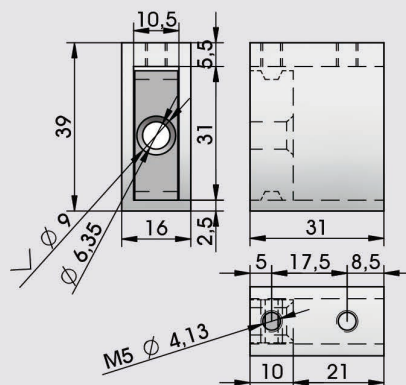

Corredera de Aluminio para Mamparas de Baño



Inox s.s. €/U

Stop cojinete
Inox brillo

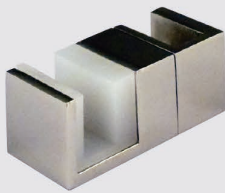

Inox s.s. 8-10 mm €/U

Guía inferior y anclaje vidrio fijo
Inox brillo
Vidrio 8-10 mm (recom: 8 mm)



Inox s.s. €/U

Anclaje carril 90°
Inox brillo



Inox s.s. 8-10 mm ∅ 12 mm €/U

Conexión 90° carril-vidrio fijo
Inox brillo
Vidrio: 8-10 mm (recom: 8 mm)

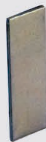

Inox s.s. €/U

Remate final carril
Inox brillo



Cu 6-10 mm ∅ 10 mm €/U

Pomo Cromado
Vidrio: 6-8-10 mm (recom: 8 mm)

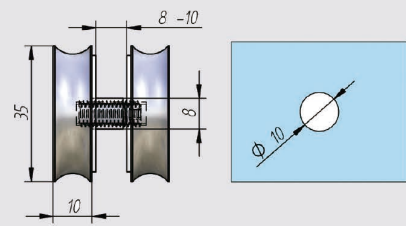
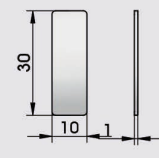
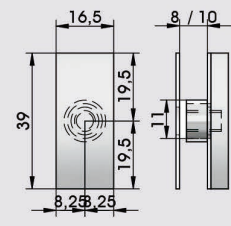
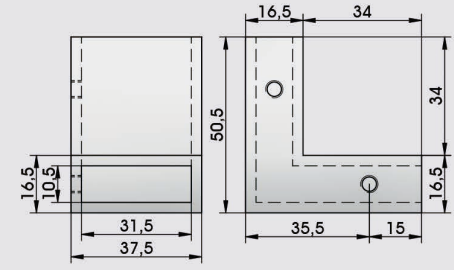
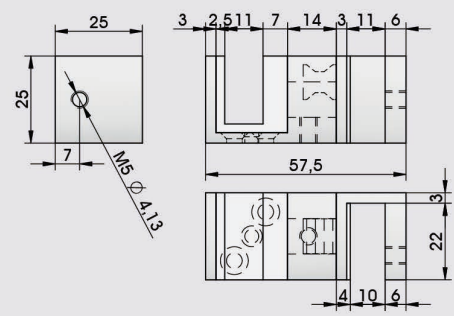
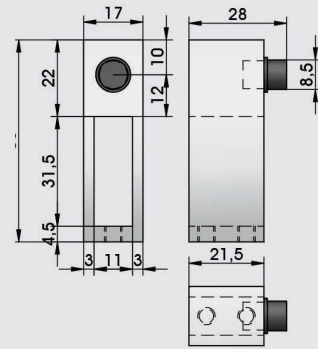

Corredera de Aluminio para Mamparas de Baño



“U” inox pulido
Barras de 3 m

inox s.s.	max. 12 mm	3 m	€/m
--------------	------------	-----	-----

15x15x15 mm
Vidrio hasta 12 mm.

inox s.s.	max. 8 mm	3 m	€/m
--------------	-----------	-----	-----

15x12x15 mm
Vidrio hasta 8mm.

inox s.s.	max. 12 mm	3 m	€/m
--------------	------------	-----	-----

25x15x25 mm
Vidrio hasta 12mm.

PVC	8-10 mm	2,2 m	€/u
-----	---------	-------	-----



Junta con imán
Para vidrio de 8-10 mm
Barras de 2,2 m

PVC	8-10 mm	2,2 m	€/u
-----	---------	-------	-----



Junta
Vidrio 8-10 mm
Barras de 2,2 m

PVC	8 mm	2,2 m	€/u
-----	------	-------	-----



Junta vidrio fijo-vidrio puerta
Vidrio 8 mm
Barras de 2,2 m

Al	2 m	€/m
----	-----	-----



Perfil burlete
Aluminio plata brillo
Barras de 2 m

